

MANIFOLD CHAMBERS & MANIFOLDS

Advice and instructions for the installation of manifold chambers and manifolds.



CONTRACT AND DIMENSIONING

The installer shall ensure that the necessary design permits have been obtained. If there is any uncertainty, the municipality and/or other responsible authority shall be contacted to verify that permission has been obtained for the specific project. Existing pipelines must have been identified and marked. Where this is sourced from another party, it must be confirmed that it has been carried out. The risk of damaging existing pipelines, both mechanically and thermally, must be taken into account when determining the location of manifolds and manifold chambers.

Excavations shall be done with adequate safety measures in case of subsidence. Trenches shall be excavated with sufficient width increase and depth for chambers and other arrangements so that pipelines and chambers, etc., can be completed as intended. Do not pile excavated material in such a way that it could collapse into the trench. Existing pipelines that are affected by excavation work shall be exposed with manual excavation. Remaining excavation and finishing in the bottom of the trench shall be done manually or with excavator bucket without teeth. The bottom should be drained with a 100 mm layer of macadam or drainage gravel. The layer around the chamber is backfilled with material that allows compression of the masses. The chamber can be installed in green areas or on cast iron lids. When installing on a cast iron lid, the appropriate overfill and cast iron lid will be required. See instructions.

It is important that the sealing ring supplied is fitted between the lid and the chamber to prevent surface water from penetrating. Pipes are insulated at least 2 metre from the chamber wall.

The chamber should be located at the highest point, as this will make it easier to refill and aerate the system from the chamber.

MANIFOLD CHAMBERS & MANIFOLDS

INSTALLATION OF CAST IRON LID

Requirements of fill height for MuoviTech's manifold chambers:

Class	Test load	Area description	Fill height requirement
A	1,5 tonnes (15 kN)	Traffic area that can only be used by pedestrians and cyclists.	30 cm
B	12,5 tonnes (125 kN)	Walkways/areas, car parking and parking decks.	30 cm
C	25 tonnes (250 kN)	Gutter areas.	30 cm
D	40 tonnes (400 kN)	Cast iron (incl. pedestrian zone, paved shoulders and parking areas.	45 cm

MuoviTech's cast iron lid is a floating telescopic cover. The asphalt around the floating cover shall cause the manifold chamber not to be loaded. It is therefore essential to ensure that it is stably integrated to distribute the traffic load away via the asphalt to the surrounding fill.



CAST IRON LID

Intended for installation in surfaces with road traffic.
 Classification: D400, 40 tonnes
 Material: Grey cast iron cover, ductile iron lid.
 Dimension: od:800, id:600, h:150

EXTENTION RING

Material: PEH
 Dimension: od:628, id:600, h:600.
 Covering and rings supplied assembled. The cover is surface water sealed. Height adjustable.

BACKFILLING AROUND CAST IRON LID

Installation and compression must be carried out in accordance with applicable rules and standards, according to local rules. The required fill height for class D400 is 45 cm.

MANIFOLD CHAMBERS & MANIFOLDS

EXCAVATION

The width of the pipe trench must be large enough for there to be room to pack and bed the pipe.

Recommended minimum spacing, A, between excavation wall and pipe is:

DN	A (cm)
< 400	35
> 400	$35 + 0,25 \times D$

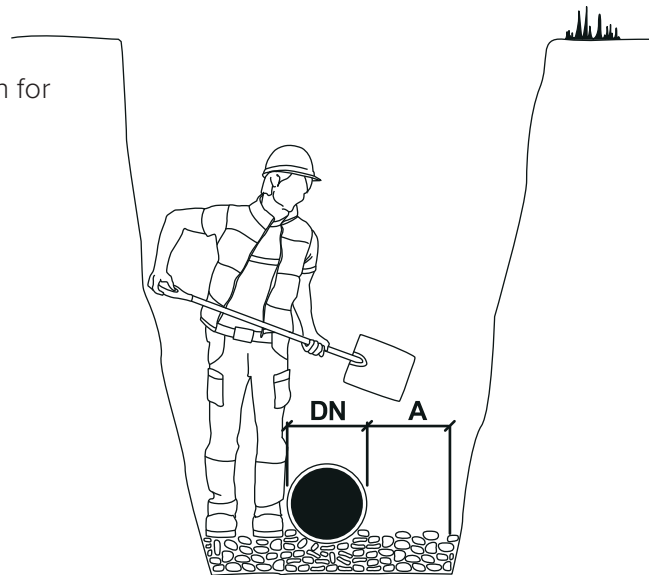

BACKFILLING

The pipe is bedded in after laying to a height of $0.2 \times D$ and then backfilled in layer thicknesses of 10-20 cm, but not more than $0.5 \times D$, up to 30 cm above the crown of the pipe.

Ensure that the pipe is not dislodged, and its height changed while bedding and packing.

Lay the backfill carefully with the bucket from the lowest possible height.

Soil must not be tipped directly onto the pipe.

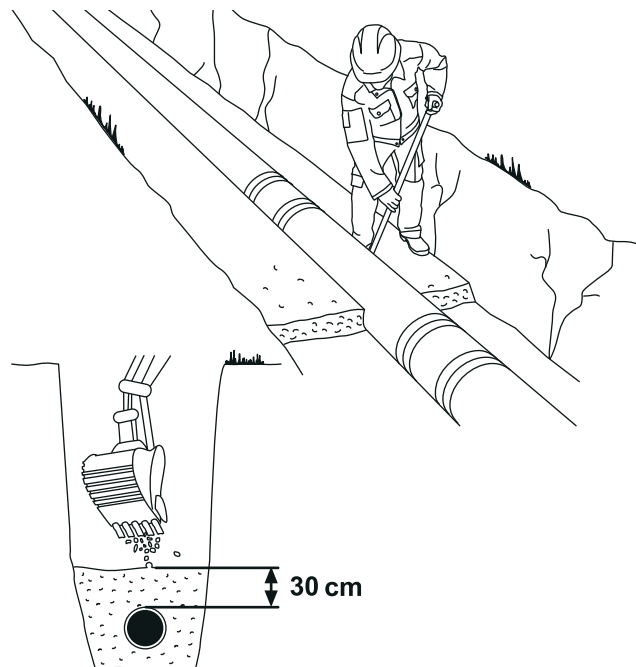

MANIFOLD CHAMBERS & MANIFOLDS

BACKFILL AND PACKING MATERIAL

A: BACKFILLING. B: Bedding.

The pipeline is backfilled preferably with one of the following materials:

Material type	Material
2	Gravel, sand, crushed aggregate
3B	Silty sand, silty gravel

Material type 2 is primarily recommended.
 Fill material shall have a maximum grain size of 32 mm.
 Frozen material must not be used.

Maximum layer thicknesses (m) when packing are:

Material type	2	3B	Min. number of passes
Vibrator rammer, 70 kg	0.30	0.25	4
Vibrator plate, 100 kg	0.15	0.10	6
Vibrator plate, 200 kg	0.20	0.15	6

When packing fill over the pipe, layer thicknesses must not be less than those indicated in the table.

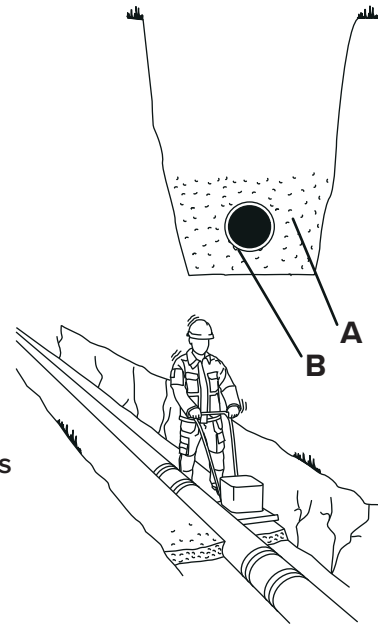

FILL AROUND CHAMBERS

Chambers must be located so far apart that it is possible to pack around them (free spacing between chambers must be at least 0.5 m). The bottom should be drained with at least a 100 mm layer of macadam or drainage gravel. The layer around the chamber is backfilled with material that allows compression of the masses. The shaft should be backfilled and packed in layers, see table above for layer thicknesses and recommended material type. The chamber surround is backfilled and packed with the same material and in the same way as for the fill around the pipe. The pipe bed thickness is adjusted under the chamber so that connected pipes are at the right level in relation to the bed. When installing cast iron lids, they should be float-fitted in a layer of at least 100mm of asphalt

